

Preparation unit——GA Series



GAC100 Series F.R.L. combination



Symbol

Reflux valve option is not available

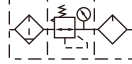

Specification

Model	GAC100M5	GAC10006
Fluid	Air	
Port size [Note1]	M5	1/8"
Filtering grade	40µm or 5µm	
Pressure range	0.15~0.9MPa(20~130psi)	
Max. pressure	1.0MPa(145psi)	
Proof pressure	1.5MPa(215psi)	
Temperature range	-5~70°C(Unfreeze)	
Capacity of drain bowl	6CC	
Capacity of oil bowl	9CC	
Recommended lubricant	ISO VG 32 or equivalent	
Weight	216g	
Constitute	Filter	GAF100M5 GAF10006
	Regulator	GAR100M5 GAR10006
	Lubricator	GAL100M5 GAL10006

[Note1] NPT thread is available.

Ordering code

GAC100 06 S W T
 ① ② ③ ④ ⑤ ⑥ ⑦ ⑧ ⑨

① Model	② Bowl material	③ Port size	④ Drain type	⑤ Type code	⑥ Pressure gauge	⑦ Filtering grade	⑧ Thread type[Note2]	⑨ Code of reflux valve
GAC100:GA100 Series F.R.L unit	Blank : PC	M5: M5 06: 1/8"	Blank: Semi-auto drain+Manual drain	S: Standard L: Lower pressure [Note1]	Blank: Circular N: No gauge	Blank: 40µm W: 5µm	T: NPT(psi/bar)	Blank: Reflux valve is not available

[Note1] The working pressure range of lower pressure type is 0.15~0.4MPa(20~58psi) ;

[Note 2] Thread type means connecting thread and scales of pressure gauge while port size is M5.

Pressure and Flow chart

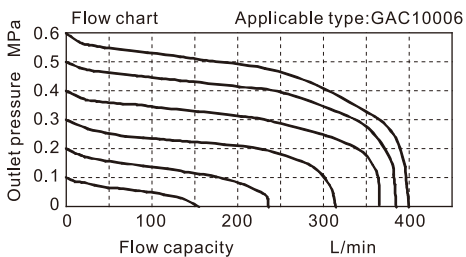
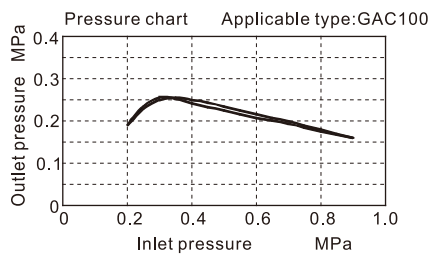

Dimensions

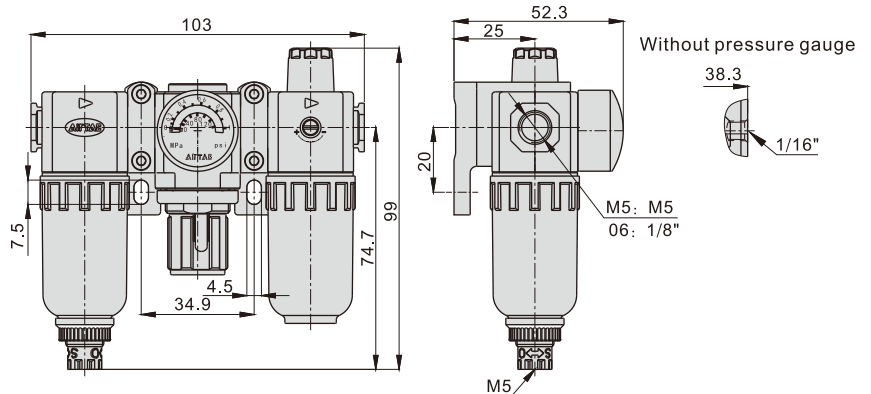

Inner structure

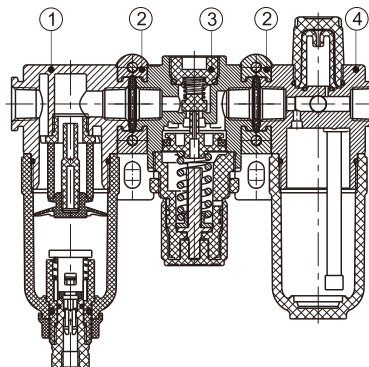

No.	Item
1	GAF100 series filter
2	Bracket
3	GAR100 series regulator
4	GAL100 series lubricator

